

# FIGHTER 5.0

**FK617-17.5"**  
145kW 4x2



**FUSO**

MODEL	W/Base	GVM	GCM
FK617HSJRFAH mwb	4270mm	9800kg	16000kg
FK617KSJRFAH lwb	4870mm	9800kg	16000kg

## ENGINE

**Mitsubishi 6D16-3AT3 Diesel (ADR80/00)**  
 Configuration: 6 Cyl. In-line OHV  
 Type: Turbocharged with Air to Air Intercooler and Catalytic Converter  
 Displacement: 7545cc  
 Bore: 118mm  
 Stroke: 115mm  
 Power (ECE R85-00): 145kW @ 2600 rpm  
 Torque (ECE R85-00): 575Nm @ 1600 rpm  
 Maximum Engine Speed: 3000 rpm  
 Compression Ratio: 18.0:1  
 Oil Cooler: Plate Type, Water Cooled

## FUEL

Pump: MD-TICS (pre-stroke control) In-line Type  
 Governor: RED-III Electronic  
 Filtration: Main Filter and Water Separator  
 Fuel Capacity: 185 Litres  
 Air Cleaner: Dual Element Cyclopac with Vertical Intake and Air Restriction Indicator

## COOLING

Fan: 520mm dia. 6 Blades  
 Fan Drive: Thermo Modulated  
 Radiator: Corrugated Fin with Expansion Tank

## ELECTRICAL

Voltage: 24V Negative Earth  
 Alternator Capacity: 24V-50 amp  
 Starter Capacity: 24V-5.0kW  
 Battery Capacity: 2x12V, 65Ah/20hr  
 Headlamp - Type: Quartz Halogen Multi Parabola  
 - Capacity: Low Beam 2x70W  
 High Beam 4x70W

## CLUTCH

**Mitsubishi C6M35**  
 Disc Diameter: 350mm  
 Type: Single Dry Plate  
 Operation: Hydraulic  
 Facing - Area: Cerametallic - 456cm<sup>2</sup>

## TRANSMISSION

**Mitsubishi M060S6-OD**  
 No. of Speeds: 6  
 Synchronesh: 2nd~6th  
 Ratios - 1st: 6.875  
 - 2nd: 4.189  
 - 3rd: 2.460  
 - 4th: 1.542  
 - 5th: 1.000  
 - 6th: 0.786  
 - Rev. 6.875  
 PTO Opening: LH Side

## PROPELLER SHAFT

Type: P8  
 Universal Joint: Needle Roller

## FRONT AXLE

**Mitsubishi F040T**  
 Type: Reverse Elliot '1' Beam  
 Capacity - Axle: 3600kg  
 Max. Load Rating at Ground: 3400kg

## REAR AXLE

**Mitsubishi R050T/D050H**  
 Type: Full Floating Hypoid  
 Capacity - Axle: 7700kg  
 Max. Load Rating at Ground: 6400kg  
 Ratio: 4.111:1

## STEERING

Type: Integral Power Assisted Ball and Nut  
 Ratio: 17.1~20.0:1  
 Steering Wheel: 450mm Urethane  
 Steering Column: Tilt/Telescopic Adjustable with Lock

## BRAKES

Type: Air Actuated Hydraulic Dual Circuit  
 Size - Front: 320x120mm  
 - Rear: 320x140mm  
 Lining - Area/Swept: Asbestos Free - 3224/5230cm<sup>2</sup>  
 Park Brake: Transmission Mounted  
 Auxiliary: Exhaust Brake  
 Compressor: Air Cooled, 201cc Single Cyl.  
 Air Dryer Model: DR4

## FRONT SUSPENSION

Type: Parabolic Leaf  
 Size: 1300x70x15mm-4 Leaves  
 Capacity at Ground: 1810kg ea.  
 Shock Absorbers: Double Acting

## REAR SUSPENSION

Type: Semi-Elliptic Leaf  
 Size: 1300x70x11mm-9 Leaves  
 Auxiliary: 900x70x10mm-7 Leaves  
 Capacity at Ground: 3500kg ea.

## CHASSIS

Type: Parallel Channel  
 Size: 228x80x7.0mm  
 Width: 840mm  
 Tensile Strength: 55kg/mm<sup>2</sup>

## WHEELS & TYRES

Wheel - Type: 7, Single Piece Disc  
 - Size: 17.5x6.00DC-135-9t  
 - Stud Pattern: 6x222.25mm PCD  
 Tyre - Size: 215/75R17.5LT 126/124M  
 Spare Tyre Carrier: Provided

## OPTIONAL EQUIPMENT

H38: 8000kg GVM Rating

## MASS (kg - estimated)

Model	Front	Rear	Total
FK617HSJRFAH	2020	1130	3150
FK617KSJRFAH	2025	1180	3205

Note: Mass (est.) includes oil and water but excludes spare wheel, tools and fuel.

## CAB FEATURES

### All Steel Forward Control

Type:	Manual Tilt 44 deg.
Mounting:	Hydroelastic Suspension 4 Point
Colour:	Natural White
Interior:	Fully Trimmed
Windscreen:	Laminated Tinted
Windscreen Wipers:	2 Speed - Intermittent Cycle
Rear Vision Mirrors:	RH. Heated
	LH. Remote/Heated with Convex Spotter
Seating Capacity:	3
Seat Belts:	2 ELR Lap Sash, 1 Lap
Seats	<u>Driver:</u> - Air Suspension with Auto Levelling Height Control
	- 32 Stage Reclining
	- 11 Stage Sliding
	- Front and Rear Height Adjuster
	- Lumbar Support
	- Integral Headrest and Fabric Trim
	<u>Centre:</u> - Low Back with Fabric Trim
	- Forward Folding
	<u>LH:</u> - Fixed Base
	- 32 Stage Reclining
	- Integral Headrest and Fabric Trim

## INSTRUMENTS

### Gauges:

- Speedometer with Odometer and Dual Tripmeter
- Tachometer
- Air Pressure (2)
- Fuel Level
- Water Temperature
- Digital Clock

### Warning Lamps:

- Turn Signal
- High Beam
- Exhaust Brake
- Park Brake
- Alternator
- Oil Filter Blockage
- Engine Control (ECU)
- Air Filter Restriction
- Door
- Cab Tilt

### Warning Lamp/Buzzer:

- Air Pressure
- Brake Fluid Level/Dual Circuit
- Oil Pressure
- Engine Overheat/Low Coolant Level

## STANDARD EQUIPMENT

- Electric Windows and Central Locking
- Tinted Side and Rear Glass
- **Air Conditioner/Heater Demister**
- AM/FM ETR Radio with Cassette and CD Player
- Centre Seat Storage Console
- LH Seat Storage Tray
- Overhead Storage Pocket with Lid
- RH Door Storage Pocket
- Rear Bunk Storage Pockets
- Cup Holders (2)
- Opening Rear Quarter Windows
- Interior Sun Visors
- Fluorescent Cabin Lamp
- Interior and Map Reading Lamps
- Key Operated Start/Fuel Control
- Engine Emergency Stop Control
- Engine Idle Speed Control
- Windscreen Washers
- Hazard Warning Lamps
- Front End-Outline Marker Lamps
- Cigar Lighter
- Roof Mounting Points (max. static load 50kg)
- Electric Horn
- Reverse Warning Buzzer
- Tool Kit
- Chassis Mounted Tool Box
- Vertical Exhaust Outlet

## DIMENSIONS (mm)

		FK617H	FK617K
		<b>SJRFAH</b>	<b>SJRFAH</b>
Width	Front Fender:	2170	2170
	Rear Axle:	2165	2165
	Front Track:	1780	1780
	Rear Track:	1660	1660
	Frame:	840	840
	Max. Recommended Body Width:	2500	2500
Length	A Overall:	7220	8095
	C Front Overhang:	1135	1135
	D Wheelbase:	4270	4870
	G Front Axle to Rear of Cab:	855	855
	H Rear of Cab to Vertical Exhaust:	210	210
Height	I Frame, Exhaust to Rear Axle:	3205	3805
	J Frame, Rear Axle to End:	1815	2090
	N Overall:	3195	3195
	P Cab to Ground:	2465	2465
	Q Cab to Frame:	1654	1654
	R Rear Frame to Ground:	850	850
		Ground Clearance:	150

## PERFORMANCE (Calculated - Paved Road)

Road Speed (km/h) at Max. Engine Speed:	132	132
Gradeability at Rated GVM:	44.4%	44.4%
Gradeability at Rated GCM:	25.2%	25.2%
Turning Circle (kerb to kerb):	13.8m	15.4m

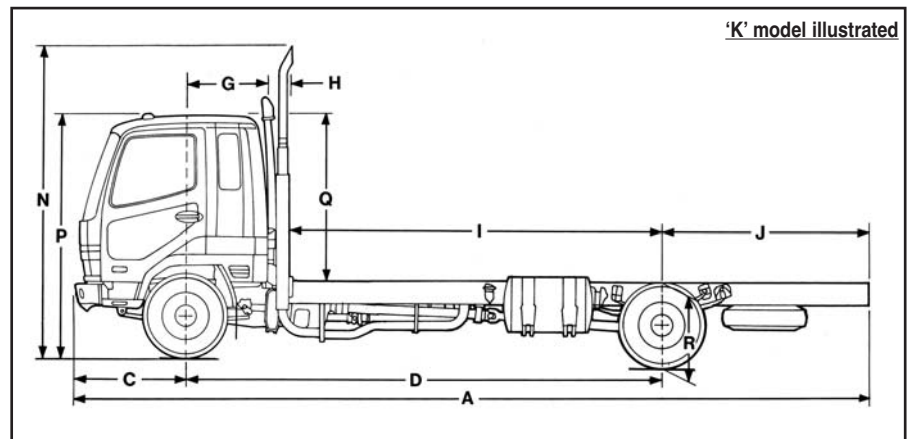
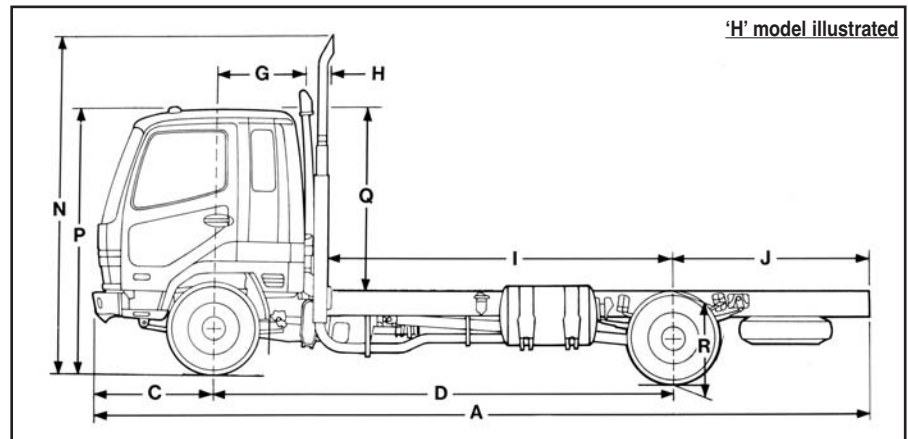

Note: Chassis reinforcement must be utilised for Tipper/Demountable type body configurations.  
To conform with ADR 13/.. and 14/.. (lighting/mirror requirements) the following must be adhered to at body installation.

- If other than a flat type or tipper body is fitted, rear end out-line marker lamps must be installed.
- If overall length exceeds 6.0 metres, side reflectors must be installed.
- If overall length exceeds 7.5 metres, side marker lamps must be installed.
- If overall width is less than 2.4 metres, the mirrors must be modified to project not more than 230mm.

"Unless specified in writing herein the accessories, applications, bodies or equipment depicted in this document are for illustration purposes only and may not be available from DaimlerChrysler Australia/Pacific Pty Ltd (ABN 23 004 411 410) ("DCAuP"). No representation or warranty whatsoever is given in relation to any accessories, applications, bodies or equipment or suitability of same that are shown herein that may be manufactured, supplied or fitted by a party other than DCAuP. DCAuP reserves the right to discontinue or make changes to the colour, designs, materials and specifications of the products and options referred to herein at any time without notice or obligation. For the most current information and in order to ascertain which accessories, applications, bodies and equipment are available from DCAuP please contact your authorised Mitsubishi FUSO truck and bus dealer."  
Copyright © DCAuP. Reproduction in whole or part prohibited without written approval.



Date: Oct. '06 Part No. T14K