

FIGHTER 8.0

FM61F
177kW 4x2

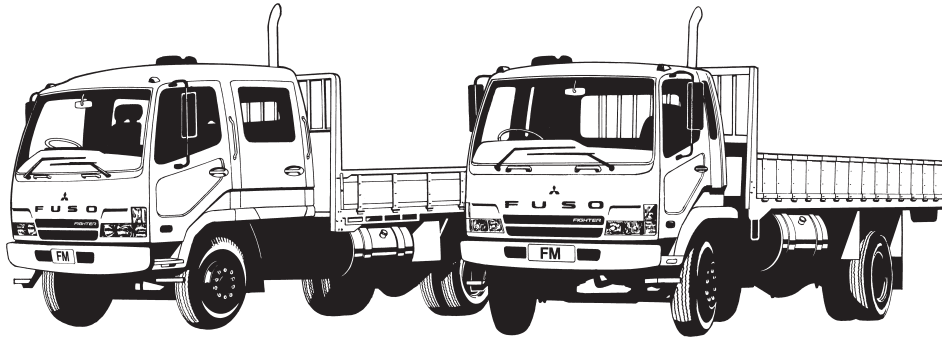

MODEL	W/Base	GVM	GCM
FM61FH1RFAE swb	4280mm	14100kg	21000kg
FM61FM1RFAE lwb	5550mm	14100kg	21000kg
FM61FMW1RFAE lwb Crew Cab	5550mm	14100kg	21000kg

ENGINE

Mitsubishi 6M60-1AT1 Diesel (ADR80/00)
 Configuration: 6 Cyl. In-line OHC, 4-Valve
 Type: Turbocharged with Air to Air Intercooler, Common Rail Fuel System and Catalytic Converter
 Displacement: 7545cc
 Bore: 118mm
 Stroke: 115mm
 Power (ECE R85-00): 177kW @ 2600 rpm
 Torque (ECE R85-00): 686Nm @ 1400 rpm
 Maximum Engine Speed: 2900 rpm
 Compression Ratio: 17.8:1
 Oil Cooler: Plate Type, Water Cooled

FUEL

Injection System: DENSO Common Rail System
 Governor: Electronic, Speed Limited to 100 km/h
 Controls: Key Operated Start/Fuel Engine Idle Emergency Stop
Cruise Control (range 40-100 km/h)
 Filtration: Main Filter and Water Separator
 Fuel Capacity: 185 Litres
 Air Cleaner: Dual Element Cyclopac with Vertical Intake and Air Restriction Indicator

COOLING

Fan: 520mm dia. 6 Blades
 Fan Drive: Thermo Modulated
 Radiator: Corrugated Fin with Expansion Tank

ELECTRICAL

Voltage: 24V Negative Earth
 Alternator Capacity: 24V-50 amp
 Starter Capacity: 24V-5.0kW
 Battery Capacity: 2x12V, 65Ah/20hr
 Headlamp - Type: Quartz Halogen Multi Parabola
 - Capacity: Low Beam 2x70W High Beam 4x70W

CLUTCH

Mitsubishi C7M38
 Disc Diameter: 380mm
 Type: Single Dry Plate
 Operation: Air Assisted Hydraulic
 Facing - Area: Cerametallic - 638.4cm²

TRANSMISSION

Mitsubishi M070S6-D
 No. of Speeds: 6 with Air Assisted Gearshift
 Synchronesh: 2nd-6th
 Ratios - 1st: 8.064
 - 2nd: 5.443
 - 3rd: 3.064
 - 4th: 1.824
 - 5th: 1.321
 - 6th: 1.000
 - Rev. 7.354
 PTO Opening: LH Side

PROPELLER SHAFT

Type: P10
 Universal Joint: Needle Roller

FRONT AXLE

Mitsubishi F060T(IH)
 Type: Reverse Elliot 'I' Beam
 Capacity - Axle: 5100kg
 Max. Load Rating at Ground: 5100kg

REAR AXLE

Mitsubishi R060T/D8H
 Type: Full Floating Hypoid
 Capacity - Axle: 9200kg
 Max. Load Rating at Ground: 9000kg
 Ratio: 4.444:1

STEERING

Type: Integral Power Assisted Ball and Nut
 Ratio: 19.05:1
 Steering Wheel: 450mm Urethane
 Steering Column: Tilt/Telescopic Adjustable with Lock

BRAKES

Type: Air Actuated Hydraulic Dual Circuit
 Size - Front: 400x120mm
 - Rear: 400x155mm
 Lining - Area/Swept: Asbestos Free - 4552/6914cm²
 Park Brake: Rear Wheel Spring Actuated
 Auxiliary: Exhaust Brake
 Compressor: Water Cooled, 154cc Single Cyl.
 Air Dryer Model: DR4

FRONT SUSPENSION

Type: Parabolic Leaf
 Size: 1400x80x17mm-4 Leaves
 Capacity at Ground: 2560kg ea.
 Shock Absorbers: Double Acting

REAR SUSPENSION

Type: Semi-Elliptic Leaf
 Size: 1400x80x11mm-9 Leaves
 Auxiliary: 960x80x11mm-9 Leaves
 Capacity at Ground: 4700kg ea.

CHASSIS

Type: Parallel Channel
 Size: 278x80x7.0mm
 Width: 840mm
 Tensile Strength: 55kg/mm²

WHEELS & TYRES

Wheel - Type: 7, Single Piece Disc
 - Size: 22.5x7.50DC-162-13t
 - Stud Pattern: 8x285mm PCD
 Tyre - Size: 275/70R22.5 148/145L
 H. Traction Tread to Rear
 Spare Tyre Carrier: Provided

OPTIONAL EQUIPMENT

R51 (MW. only): Engine Flywheel PTO
 Max. Output Torque, 295Nm
 Drive Ratio, 0.628:1
 Rotation, Same as Engine

MASS (kg - estimated)

Model	Front	Rear	Total
FM61FH1RFAE	2495	1605	4100
FM61FM1RFAE	2555	1685	4240
FM61FMW1RFAE	2780	1725	4505

Note: Mass (est.) includes oil and water but excludes spare wheel, tools and fuel.

CAB FEATURES

All Steel Forward Control

- Type: H, M. Manual Tilt 44 deg.
MW. Elec/Hyd. Tilt 44 deg.
- Mounting: H, M. Hydroelastic Suspension 4 Point
MW. Isolated Rubber 3 Point
- Colour: Natural White
- Interior: Fully Trimmed
- Windscreen: Laminated Tinted
- Windscreen Wipers: 2 Speed - Intermittent Cycle
- Rear Vision Mirrors: RH. Heated
LH. Remote/Heated with Convex Spotter
- Seating Capacity: H, M. 3
MW. 7
- Seat Belts: H, M. 2 ELR Lap Sash, 1 Lap
MW. 4 ELR Lap Sash, 3 Lap
- Seats Driver: - Air Suspension with Auto
Levelling Height Control
- 32 Stage Reclining
- 11 Stage Sliding
- Front and Rear Height Adjuster
- Lumbar Support
- Integral Headrest and Fabric Trim
- Centre: - Low Back with Fabric Trim
- Forward Folding
- LH: - Fixed Base
- 32 Stage Reclining
- Integral Headrest and Fabric Trim
- Rear MW: - Bench Type
- Low Back with Fabric Trim

INSTRUMENTS

Gauges:

- Speedometer with Odometer and Dual Tripmeter
- Tachometer
- Air Pressure (2)
- Fuel Level
- Water Temperature
- Digital Clock

Warning Lamps:

- Turn Signal
- High Beam
- Exhaust Brake
- Park Brake
- Alternator
- Oil Filter Blockage
- Engine/Cruise Control (ECU)
- Air Filter Restriction
- Door
- Cab Tilt (MW. inc's buzzer)

Warning Lamp/Buzzer:

- Air Pressure
- Brake Fluid Level/Dual Circuit
- Oil Pressure
- Engine Overheat/Low Coolant Level

STANDARD EQUIPMENT

- Electric Windows (front only) and Central Locking
- Tinted Side and Rear Glass
- **Air Conditioner/Heater Demister**
- AM/FM ETR Radio with Cassette and CD Player
- Centre Seat Storage Console (except MW)
- LH Seat Storage Tray
- Overhead Storage Pocket with Lid (H, M)
- Overhead Storage Pocket (MW)
- RH Door Storage Pocket
- Rear Bunk Storage Pockets (except MW)
- Cup Holders, 2 (except MW)
- Opening Rear Quarter Windows (except MW)
- Interior Sun Visors
- Fluorescent Cabin Lamp (except MW)
- Interior and Map Reading Lamps
- Windscreen Washers
- Hazard Warning Lamps
- Front End-Outline Marker Lamps
- Cigar Lighter
- Roof Mounting Points (max. static load 50kg)
- Electric Horn
- Reverse Warning Buzzer
- Tool Kit
- Chassis Mounted Tool Box
- Vertical Exhaust Outlet

DIMENSIONS (mm)

		FM61FH	FM61FM	FM61FMW
		1RFAE	1RFAE	1RFAE
Width	Front Fender:	2370	2370	2370
	Rear Axle:	2420	2420	2420
	Front Track:	1880	1880	1880
	Rear Track:	1815	1815	1815
	Frame:	840	840	840
	Length	A Overall:	7455	9325
C Front Overhang:		1245	1245	1245
D Wheelbase:		4280	5550	5550
G Front Axle to Rear of Cab:		745	745	1445
H Rear of Cab to Vertical Exhaust:		210	210	235
I Frame, Exhaust to Rear Axle:		3325	4595	3870
J Frame, Rear Axle to End:		1930	2530	2530
Height		N Overall:	3365	3365
	P Cab to Ground:	2640	2640	2710
	Q Cab to Frame:	1654	1654	1736
	R Rear Frame to Ground:	1025	1025	1025
	Ground Clearance:	220	220	220

PERFORMANCE (Calculated - Paved Road)

Electronically Speed Limited to (km/h):	*100	*100	*100
Gradeability at Rated GVM:	36.4%	36.4%	36.4%
Gradeability at Rated GCM:	23.2%	23.2%	23.2%
Turning Circle (kerb to kerb):	14.4m	18.0m	20.0m

*Conforms to ADR 65/..

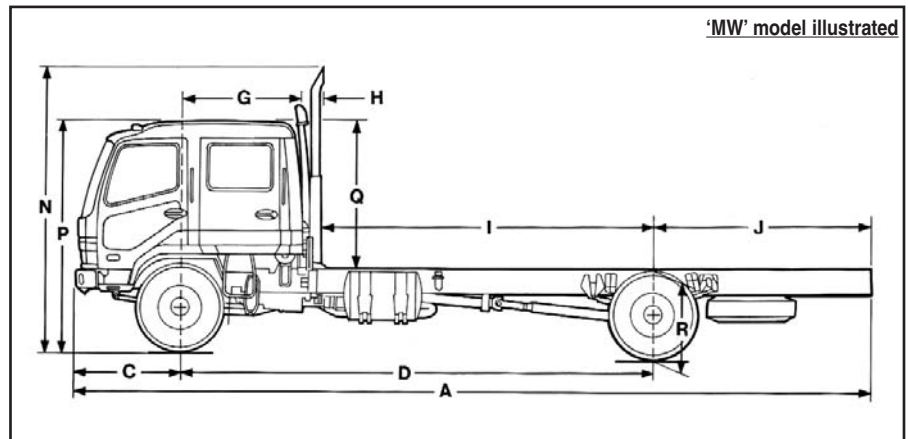
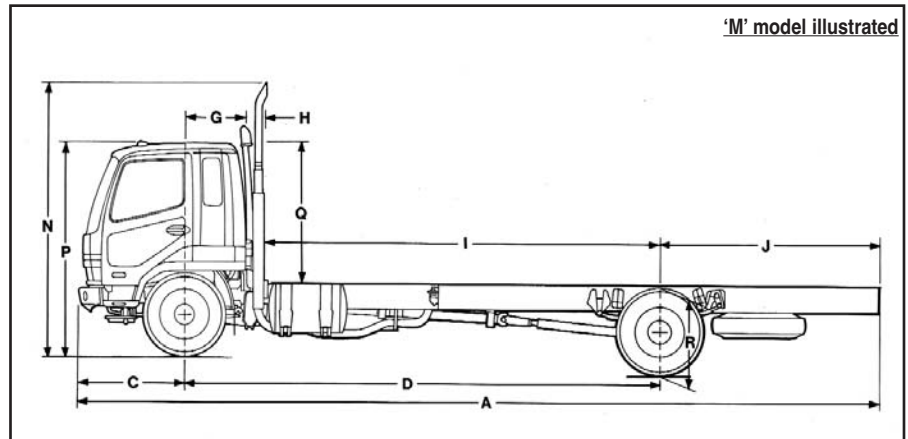

Note: Chassis reinforcement must be utilised for Tipper/Demountable type body configurations.

To conform with ADR 13/.. (lighting requirements) the following must be adhered to at body installation.

- Reflective rear marker plates must be installed.
- If other than a flat type or tipper body is fitted, rear end out-line marker lamps must be installed.
- If overall length exceeds 6.0 metres, side reflectors must be installed.
- If overall length exceeds 7.5 metres, side marker lamps must be installed.

"Unless specified in writing herein the accessories, applications, bodies or equipment depicted in this document are for illustration purposes only and may not be available from DaimlerChrysler Australia/Pacific Pty Ltd (ABN 23 004 411 410) ("DCAuP"). No representation or warranty whatsoever is given in relation to any accessories, applications, bodies or equipment or suitability of same that are shown herein that may be manufactured, supplied or fitted by a party other than DCAuP. DCAuP reserves the right without notice or obligation to discontinue or make changes to the colour, designs, materials and specifications of the products and options referred to herein at any time. For the most current information and in order to ascertain which accessories, applications, bodies and equipment are available from DCAuP please contact your authorised Mitsubishi FUSO truck and bus dealer."
Copyright © DCAuP. Reproduction in whole or part prohibited without written approval.

Date: Oct. '06 Part No. T19M

