

FP 4x2 SERIES

FP54J
257kW

with AIR SUSPENSION

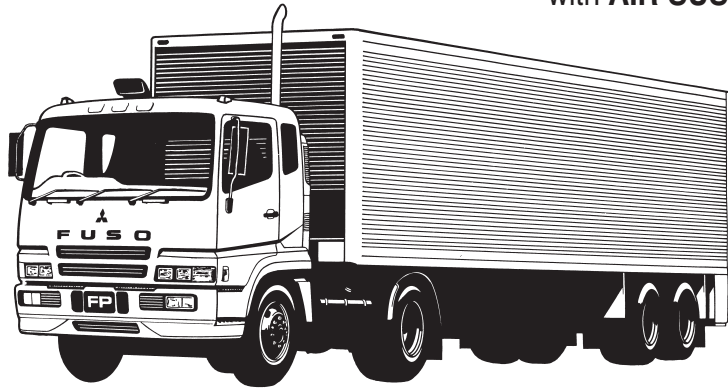

MODEL
FP54JGR2RFAA swb

W/Base
3800mm

GVM
16000kg

GCM
40000kg

ENGINE

Mitsubishi 6M70-1AT2 Diesel (ADR80/00)
 Configuration: 6 Cyl. In-line OHC, 4 Valve
 Type: Turbocharged with Air to Air Intercooler and Common Rail Fuel System
 Displacement: 12882cc
 Bore: 135mm
 Stroke: 150mm
 Power (ECE R85-00): 257kW @ 2200 rpm
 Torque (ECE R85-00): 1520Nm @ 1200 rpm
 Maximum Engine Speed: 2300 rpm
 Compression Ratio: 17.5:1
 Oil Cooler: Plate Type, Water Cooled

FUEL

Injection System: BOSCH Common Rail System
 Governor: Electronic, Speed Limited to 100 km/h
 Controls: Key Operated Start/Fuel Engine Idle Emergency Stop
Cruise Control (range 40-100 km/h)
 Filtration: Main Filter and Water Separator
 Tank Type: Rectangular Aluminium
 Fuel Capacity: 400 Litres
 Air Cleaner: Dual Element Dry Paper Type with Vertical Intake and Air Restriction Indicator

COOLING

Fan: 700mm dia. 8 Blades
 Fan Drive: Thermo Modulated
 Radiator: Corrugated Fin with Expansion Tank

ELECTRICAL

Voltage: 24V Negative Earth
 Alternator Capacity: 24V-50 amp
 Starter Capacity: 24V-5.5kW
 Battery Capacity: 2x12V, 150Ah/20hr
 Headlamp - Type: Rectangular Quartz Halogen
 - Capacity: Low Beam 2x70W High Beam 2x75W, 2x70W

CLUTCH

Mitsubishi C12W43P
 Disc Diameter: 430mm
 Type: Pull Type, Single Dry Plate
 Operation: Air Assisted Hydraulic
 Facing - Area: Asbestos Free - 1920cm²

TRANSMISSION

Mitsubishi M130S2x5
 No. of Speeds: 10 with Air Assisted Gearshift
 Synchronesh: 2nd~5th
 Oil Cooler: Oil to Air, Countershaft Driven Oil Pump
 Low High
 Ratios - 1st: 9.153 7.005
 - 2nd: 5.444 4.166
 - 3rd: 3.080 2.357
 - 4th: 1.762 1.349
 - 5th: 1.000 0.765
 - Rev. 7.929 6.068
 PTO Opening: LH Side

PROPELLER SHAFT

Type: P140
 Universal Joint: Needle Roller

FRONT AXLE

Mitsubishi F090T
 Type: Reverse Elliot 'I' Beam
 Capacity - Axle: 6500kg
 Max. Load Rating at Ground: 6000kg (std tyres)
 6500 kg (295/80R22.5 ref. tyre placard)

REAR AXLE

Mitsubishi R12T/D12H
 Type: Full Floating Hypoid
 Capacity - Axle: 10800kg
 Max. Load Rating at Ground: 10800kg
 Ratio: 4.625:1

STEERING

Type: Integral Power Assisted Ball and Nut
 Ratio: 22.4:1
 Steering Wheel: 480mm Urethane
 Steering Column: Tilt/Telescopic Adjustable with Lock

BRAKES

Type: Full Air, Dual Circuit, Mitsubishi Taper Roller with Automatic Brake Adjustment
 Size - Front: 410x150mm
 - Rear: 410x200mm
 Lining - Area/Swept: Asbestos Free - 5820/9020cm²
 Park Brake: Rear Wheel Spring Actuated
 Auxiliary: Exhaust Brake
 Trailer: Hand Control Valve, Air Lines and Electrical Cord
 Compressor: Water Cooled, 340cc Single Cyl.
 Air Dryer Model: DR2

FRONT SUSPENSION

Type: Parabolic Leaf with Stabiliser Bar
 Size: 1650x90x16mm-4 Leaves
 Capacity at Ground: 3250kg ea.
 Shock Absorbers: Double Acting

REAR SUSPENSION (Air)

Type: Trailing Arm with Air Dump Control
 RFCN: RF2038
 Air Spring: 2x300mm dia.
 Trailing Arm: (665+430)x90x35mm-2 Leaves
 Capacity at Ground: 11000kg total
 Shock Absorbers: Double Acting

CHASSIS

Type: Reinforced Parallel Channel
 Size: 276x90x6.0mm
 Width: 840mm
 Tensile Strength: 55kg/mm²

WHEELS & TYRES

Wheel - Type: 7, Single Piece Disc
 - Size: 22.5x8.25DC-165-12t
 - Stud Pattern: 10x335mm PCD
 Tyre - Size: 11R22.5 148/145L
 Spare Tyre Carrier: Not Provided

OPTIONAL EQUIPMENT

R01: 800 Litre (2x400L) Fuel Capacity

MASS (kg - estimated)

Model	Front	Rear	Total
FP54JGR2RFAA	3875	1715	5590

Note: Mass (est.) includes oil and water but excludes spare wheel, tools and fuel.

CAB FEATURES

All Steel Forward Control

Type:	Elec/Hyd. Tilt 50 deg.
Mounting:	Coil Suspension, 4 Point
Colour:	Natural White
Interior:	Fully Trimmed
Windscreens:	Laminated Tinted
Windscreens Wipers:	2 Speed - Intermittent Cycle
Rear Vision Mirrors:	RH. Heated LH. Remote/Heated with Convex Spotter
Seating Capacity:	2
Seat Belts:	2 ELR Lap Sash
Seats	<u>Driver:</u> - Air Suspension with Auto Levelling Height Control - 32 Stage Reclining - 15 Stage Sliding - Front and Rear Height Adjuster - Lumbar Support - Headrest and Fabric Trim <u>LH:</u> - Fixed Base - 32 Stage Reclining - Headrest and Fabric Trim

INSTRUMENTS

- Gauges:
- Speedometer with Odometer and Tripmeter
 - Tachometer
 - Air Pressure (2)
 - Fuel Level
 - Water Temperature
 - Digital Clock
- Warning Lamps:
- Turn Signal
 - High Beam
 - Exhaust Brake
 - Park Brake
 - Trailer Brake
 - Alternator
 - Oil Filter Blockage
 - Engine/Cruise Control (ECU)
 - High/Low Range
 - Air Filter Restriction
 - Door
- Warning Lamp/Buzzer:
- Air Pressure/Brake Dual Circuit
 - Oil Pressure
 - Engine Overheat/Low Coolant Level
 - Engine Overrun
 - Cab Tilt
 - Air Rear Suspension

STANDARD EQUIPMENT

- Electric Windows and Central Locking
- Door Side Impact Beams
- Tinted Side and Rear Glass
- **Auto 'Climate Contol' Air Conditioner**
- Sleeper Mattress and Curtains
- AM/FM ETR Radio with Cassette and CD Player
- Centre Storage Console
- LH Seat Storage Tray
- LH/RH Overhead Storage Pocket with Lid
- Cup Holder
- Opening Rear Quarter Windows
- Interior Sun Visors
- Fluorescent Cabin Lamp with Dash Control
- Windscreen Washers
- Hazard Warning Lamps
- Front End-Outline Marker Lamps
- QH Fog Lamps
- Cigar Lighter
- Roof Mounting Points (max. static load 50kg)
- Dual Air Horns
- Reverse Warning Buzzer
- Wheel Changing Tools
- Vertical Exhaust Outlet
- Stainless Steel Mufflershield
- Chrome Exhaust Tailpipe
- Front Bumper Air Dam

DIMENSIONS (mm)

		FP54JGR
		2RFAA
Width	Front Fender:	2490
	Rear Axle:	2460
	Front Track:	2045
	Rear Track:	1845
	Frame:	840
Length	A Overall:	6115
	C Front Overhang:	1370
	D Wheelbase:	3800
	G Front Axle to Rear of Cab:	770
	H Rear of Cab to Vertical Exhaust:	296
	I Frame, Exhaust to Rear Axle:	2734
	J Frame, Rear Axle to End:	945
Height	N Overall:	3740
	O Air Intake to Cab Roof:	360
	P Cab to Ground:	2870
	Q Cab to Frame:	1920
	R Rear Frame to Ground, Suspension - Inflated:	987
	- Deflated:	937
	Ground Clearance:	234

PERFORMANCE (Calculated - Paved Road)

Electronically Speed Limited to (km/h):	*100
Gradeability at Rated GVM:	#
Gradeability at Rated GCM:	30.0%
Turning Circle (kerb to kerb):	13.4m
*Conforms to ADR 65/..	
#Exceeds Traction	

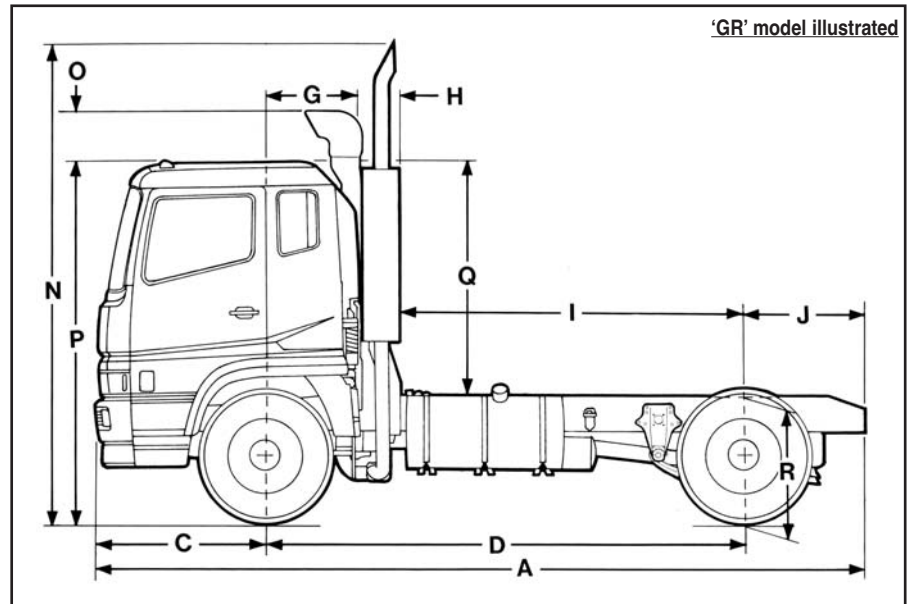

- Note: Chassis reinforcement must be utilised for other than 4x2 Tractor applications.
- To conform with ADR 13/.. (lighting requirements) the following must be adhered to at body installation.
 - Reflective rear marker plates must be installed.
 - If other than a flat type or tipper body is fitted, rear end out-line marker lamps must be installed.
 - If overall length exceeds 6.0 metres, side reflectors must be installed.
 - If overall length exceeds 7.5 metres, side marker lamps must be installed.

"Unless specified in writing herein the accessories, applications, bodies or equipment depicted in this document are for illustration purposes only and may not be available from DaimlerChrysler Australia/Pacific Pty Ltd (ABN 23 004 411 410) ("DCAuP"). No representation or warranty whatsoever is given in relation to any accessories, applications, bodies or equipment or suitability of same that are shown herein that may be manufactured, supplied or fitted by a party other than DCAuP. DCAuP reserves the right without notice or obligation to discontinue or make changes to the colour, designs, materials and specifications of the products and options referred to herein at any time. For the most current information and in order to ascertain which accessories, applications, bodies and equipment are available from DCAuP please contact your authorised Mitsubishi FUSO truck and bus dealer." Copyright © DCAuP. Reproduction in whole or part prohibited without written approval.

Date: Oct. '06 Part No. T24M

